

100107

Legend

ROUTING SEQUENCE:
100107 (ASSEMBLE SWIVEL)

REVISIONS				
ZONE	REV	DESCRIPTION	DATE	APPROVED
1	A	Change tolerances from 45 IN./LB. TORQUE to 20-30 IN./LB. TORQUE per ECN "TORQUE NON RETURN SWIVELS".	04/03/00	FC
2	B	Plate width changed from 6.875 ref. to 6.900±.050.	04/26/01	FC
3	C	Removed tolerances on dimensions as shown and added note on tolerances for components.	12/03/05	MAS

****NOTE: For tolerances on components see specific components.**

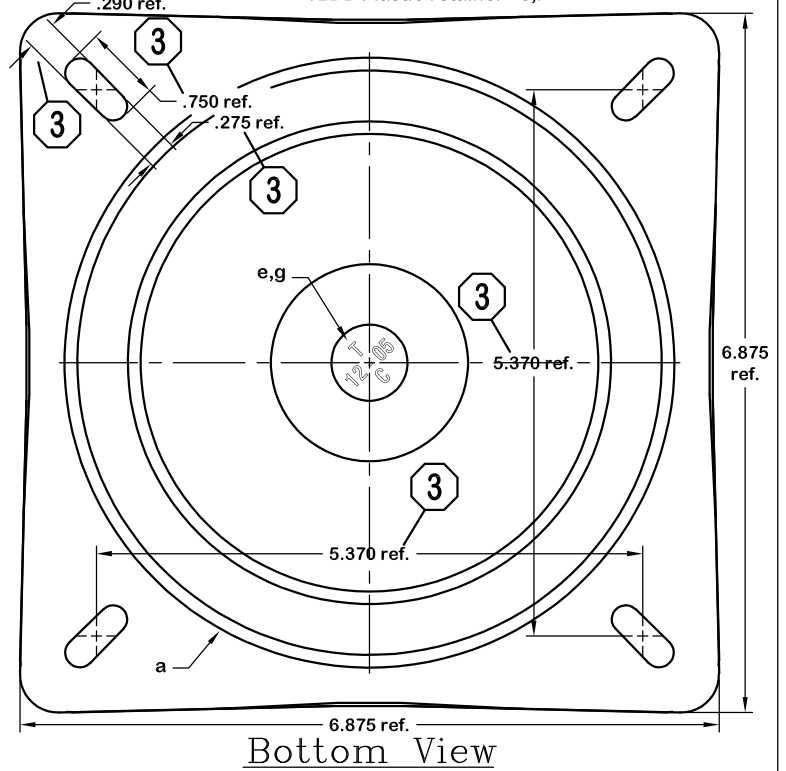
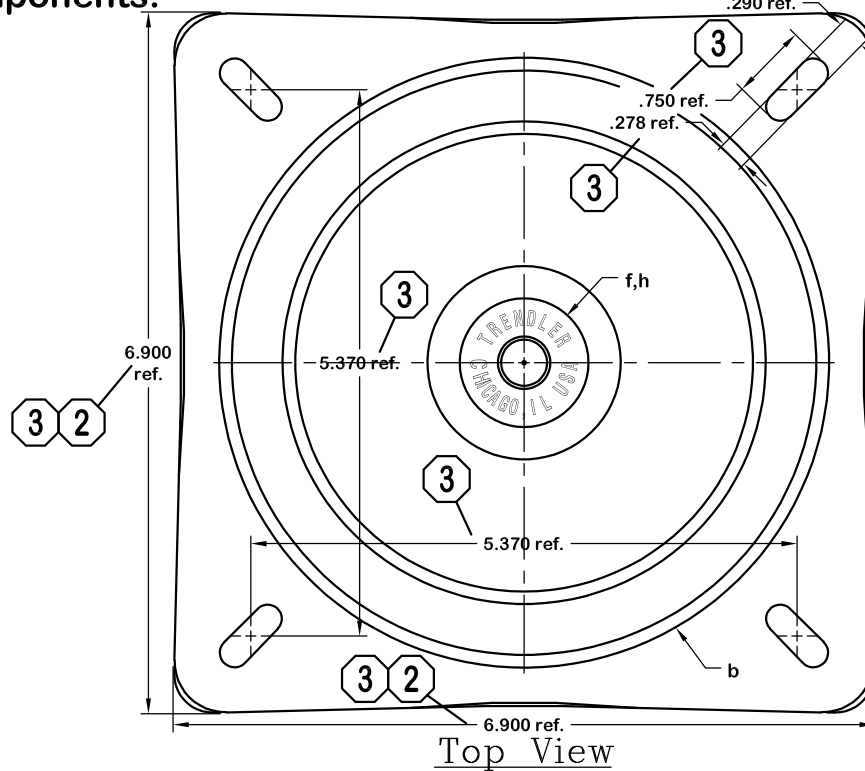
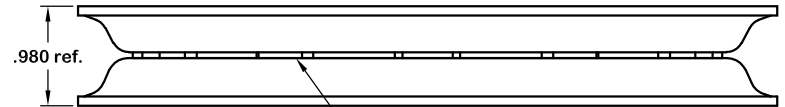
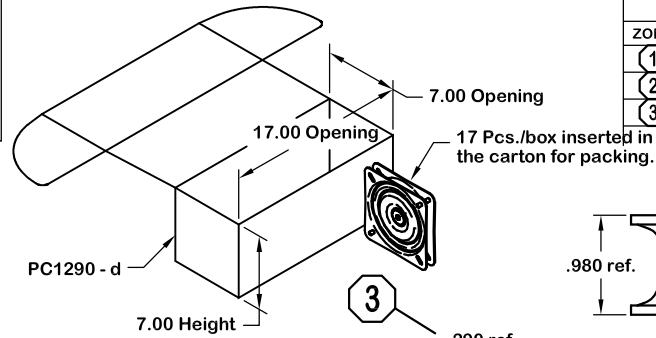

Material Specifications

SWIVEL TENSION - 20-30 IN./LB. TORQUE
LOAD CAPACITY - 500 LB.

TEST STANDARDS (TC):

- TENSION TEST (TORQUE)
- ANSI/BIFMA X5.1-1993:
- BACK STRENGTH TEST - STATIC - TYPE IIA
- BACK DURABILITY TEST - CYCLIC - TYPE IIA & IIB
- SWIVEL TEST - CYCLIC

BOM

QTY (U/M):	
1.000 ea	a. 200049:PLB 712 NF
1.000 ea	b. 200107:PLT 712 FL NF
1.000 ea	c. 300008:PLASTIC RETAINER FOR 7"
0.059 ea	d. PC1290:CTN SWL 17.00 x 7.00 x 7.00
1.000 ea	e. PF2010:RIVET .362 x .375 HDX SWL
1.000 ea	f. PF3090:WASHER SPACER 1.2680D x .375
1.000 ea	g. PF5010:WASHER SPACER .375ID x .750D
0.013 lb	h. PG1100:Grease Swivel #725
1.000 ea	i. PP1010:PLASTIC NYLATRON WSHR 1.25 x
12.00 ea	j. PZ1000:BALL BEARING 5/16 CARBON STL

UNLESS OTHERWISE SPECIFIED DIMENSIONS ARE IN DECIMAL INCHES & TOLERANCES ARE SHOWN ON THE DRAWING OR BELOW.

TOLERANCES ARE:		
FRACTIONS	ANGLES	DECIMALS
±	±	.XX ±
		.XXX ±



712 FL 12BB NF

Trendler, Inc.

4540 West 51st Street Chicago, Illinois 60632 Phone: 773-284-6600

Web Site: www.trendler.com Fax: 773-581-6250

DRAWN BY: MAS	DRAWING NO: 100107	LAST UPDATE:
DATE: 03/12/99	SCALE: No Scale	

CRITICAL DIMENSIONS ARE IN BOLD LETTERING