

SALICE Concealed Hinges, 165° Series 200

165° Self-Close Series 200 Euro Hinges

- Self-closing
- 11mm cup depth
- 35mm cup diameter
- Plates sold separately



Use the formulas below to determine the type of hinge arm, the drilling distance "K" and the mounting plate "H" necessary for the application.

- K** = drilling distance (3mm - 8mm)
- H** = mounting plate height
- D** = overlay of door on side panel or frame
- A** = reveal
- T** = door thickness
- S** = thickness of cabinet panel

165° - Full Overlay "A" Crank

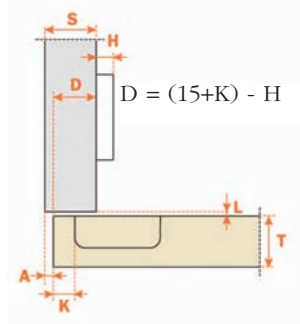

- SAC2PFA99** Screw on
- SAC2RFA99** Press in
- SAC27FA99** Rapido
- SAC2JFA99** Logica

165° - 1/2" Overlay "D" Crank

Popular for use with face frame cabinets

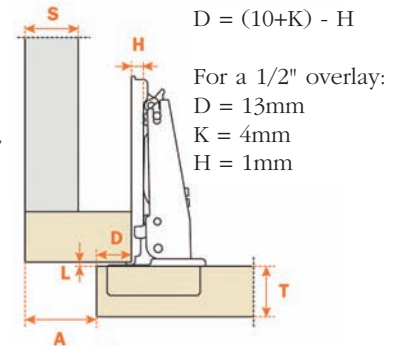

- Hinge**
- SAC2PFD99** Screw on
 - SAC2RFD99** Press in
 - 1mm Plate for 1/2" OL**
 - SABAU3L19** Single cam
 - SABAU3R19** Double cam

165° - Half Overlay "G" Crank

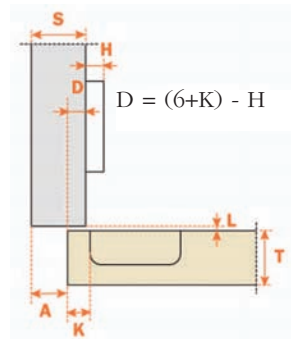

- SAC2PFG99** Screw on
- SAC2RFG99** Press in

165° - Inset "P" Crank

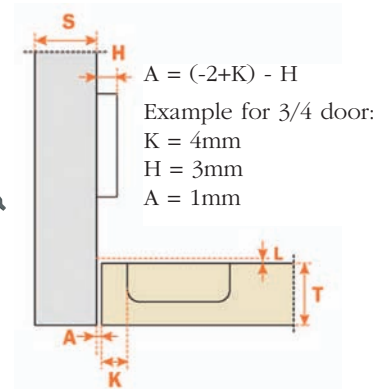

- SAC2PPF99** Screw on
- SAC2RPF99** Press in

Millimeter to inch equivalents

1	1.5	2	3	4	5	5.5	6	7	8	9	9.5	10	11	12	13	14	15	16	17	17.5	18	19	20	20.5	21	22	23	24	24.5	25.4
1/32	1/16	3/32	1/8	5/32	3/16	7/32	1/4	9/32	5/16	11/32	3/8	13/32	7/16	15/32	1/2	9/16	19/32	5/8	21/32	11/16	23/32	3/4	25/32	13/16	27/32	7/8	29/32	15/16	31/32	1