

# CLIP top BLUMOTION 95° inset blind corner hinges



## Features

- BLUMOTION integrated into the hinge cup
- Deactivation switch for small/light doors
- New INSERTA design
- Boring distance range 3 mm to 7 mm
- Compatible with existing CLIP mounting plates and hinge arm cover caps
- Press-in hinges must be inserted with knock-in tool or universal insertion ram

Minimum reveal table						
3	0.1	0.3	0.4	0.5	0.9	1.3
4	0.1	0.3	0.4	0.5	0.9	1.3
5	0.1	0.4	0.4	0.5	0.9	1.3
6	0.1	0.3	0.4	0.5	0.9	1.2
7	0.1	0.3	0.4	0.5	0.9	1.2
B = boring dist.	16	18	19	20	22	24

T = door thickness

## Flush door applications

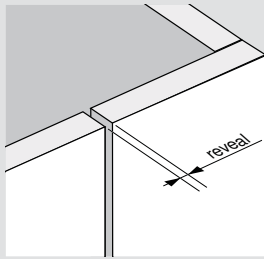

Back of door is flush with stationary panel

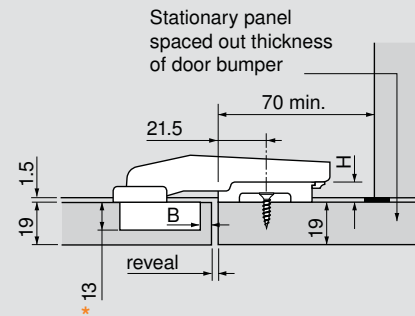

## Offset door applications

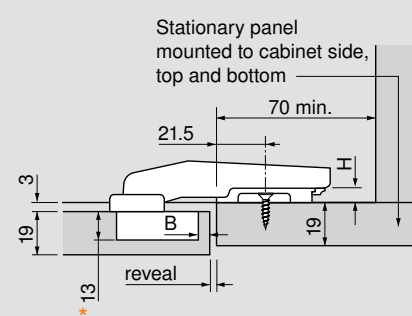
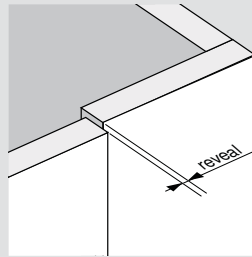

## Adjustments and clearances

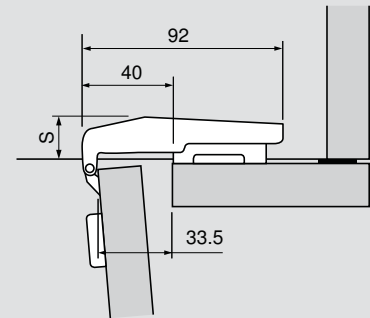
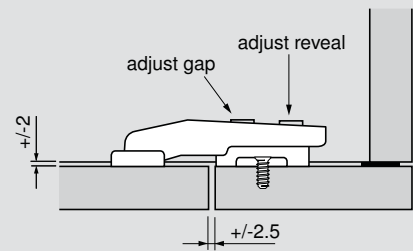

\* All 35 mm and 8 mm holes must be a minimum of 13 mm deep

H	Reveal					P	S
3	5	4	3	2	1	33.5	21
	3	4	5	6	7		
	B = boring distance						

H	Reveal					P	S
0	5	4	3	2	1	33.5	21
	3	4	5	6	7		
	B = boring distance						

## Abbreviations

H	=	Plate height
P	=	Door protrusion
S	=	Side arm protrusion

Flush door	Self close
Screw-on	79B9550
Press-in	79B9580
INSERTA	79B9590

Offset door	Self close
Screw-on	79B9550
Press-in	79B9580
INSERTA	79B9590