

# 100116

## Legend

ROUTING SEQUENCE:  
100116(ASSEMBLE SWIVEL)

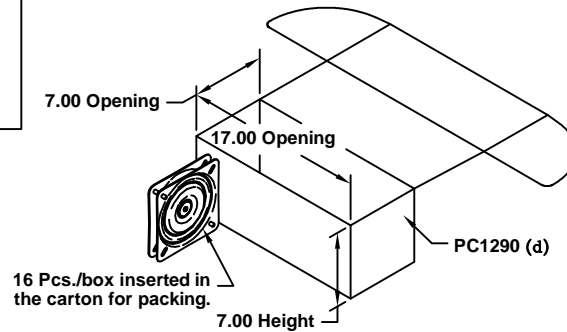

REVISIONS				
ZONE	REV	DESCRIPTION	DATE	APPROVED
1	A	Change tolerances from 45 IN./LB. TORQUE to 20-30 IN./LB. TORQUE per ECN "TORQUE NON RETURN SWIVELS".	04/03/00	FC
2	B	Modify 200094 die to extend 2 slots by 1/16 per ECN#200094-2.	04/25/07	YD

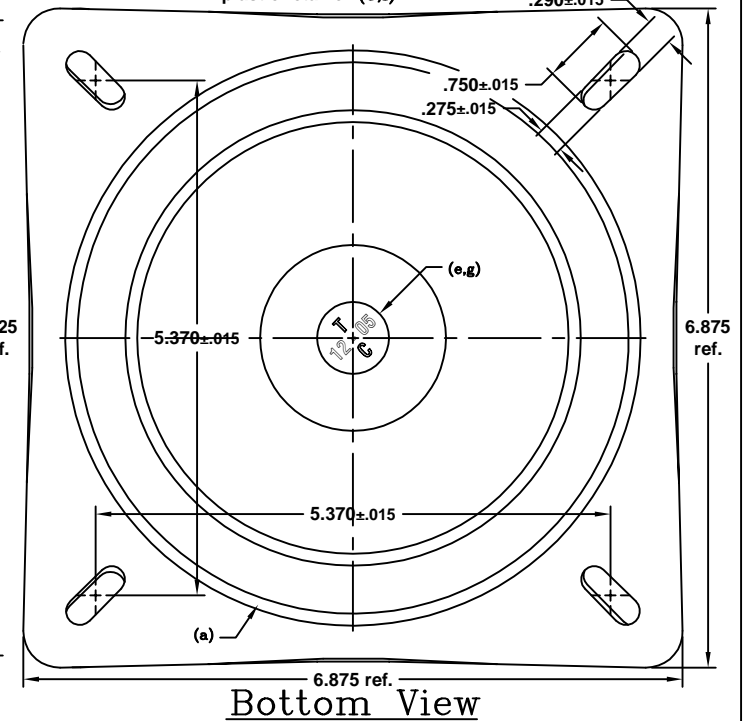
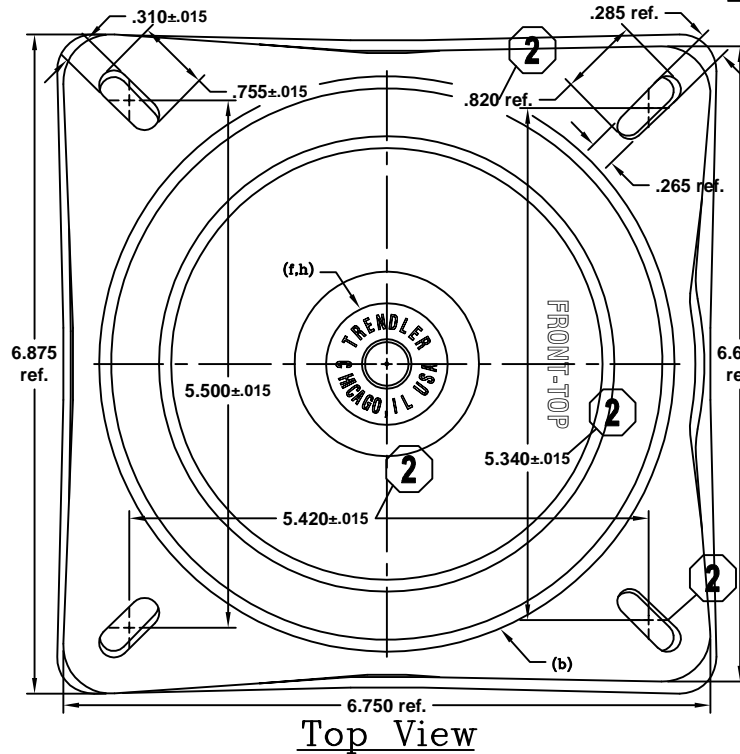
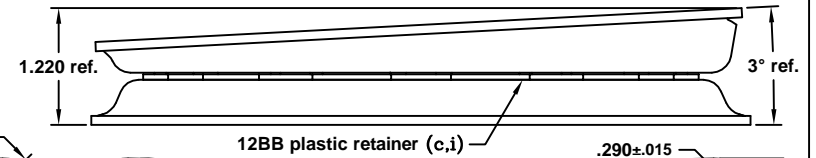

## Material Specifications

SWIVEL TENSION - 20-30 IN./LB. TORQUE  
LOAD CAPACITY - 500 LB.

TEST STANDARDS (TC):  
- TENSION TEST (TORQUE)

ANSI/BIFMA X5.1-1993:  
- BACK STRENGTH TEST - STATIC - TYPE IIA  
- BACK DURABILITY TEST - CYCLIC - TYPE IIA & IIB  
- SWIVEL TEST - CYCLIC

### BOM:

- (a)-200049:PLB 712 NF
- (b)-200094:PLT 712 3D NF
- (c)-300008:PLASTIC RETAINER FOR 7"
- (d)-PC1290:CTN SWL 17.00 x 7.00 x 7.00
- (e)-PF2010:RIVET .362 x .75 HDX SWL
- (f)-PF3090:WASHER SPACER 1.2680D x .375
- (g)-PF5010:WASHER SPACER .375ID x .750D
- (\*)-PG1100:Grease Swivel #725
- (h)-PP1010:PLASTIC NYLATRON WSHR 1.25 x
- (i)-PZ1000:BALL BEARING 5/16 CARBON STL

### QTY:

- 1,000 ea.
- 1,000 ea.
- 1,000 ea.
- 0.063 ea.
- 1,000 ea.
- 1,000 ea.
- 1,000 ea.
- 0.013 lb.
- 1,000 ea.
- 12.00 ea.

UNLESS OTHERWISE SPECIFIED DIMENSIONS ARE IN DECIMAL INCHES & TOLERANCES ARE SHOWN ON THE DRAWING OR BELOW.

TOLERANCES ARE:  
FRACTIONS ANGLES DECIMALS  
± ± .XX ±  
.XXX ±



## 712 3D 12BB NF

**Trendler, Inc.**

4540 West 51st Street Chicago, Illinois 60632

Phone: 773-284-6600  
Fax: 773-581-6250  
Web Site: www.trendler.com

DRAWN BY: MAS DRAWING NO: 100116

DATE: 12/19/98 SCALE: No Scale

LAST UPDATE:

CRITICAL DIMENSIONS ARE IN BOLD LETTERING