

■ Configuration of fitting

Depending on the force adjustment, a variety of positions can be achieved with the 4 mm allen screw (b), from simply braking the door when dropping to the intermediate positioning of the door.

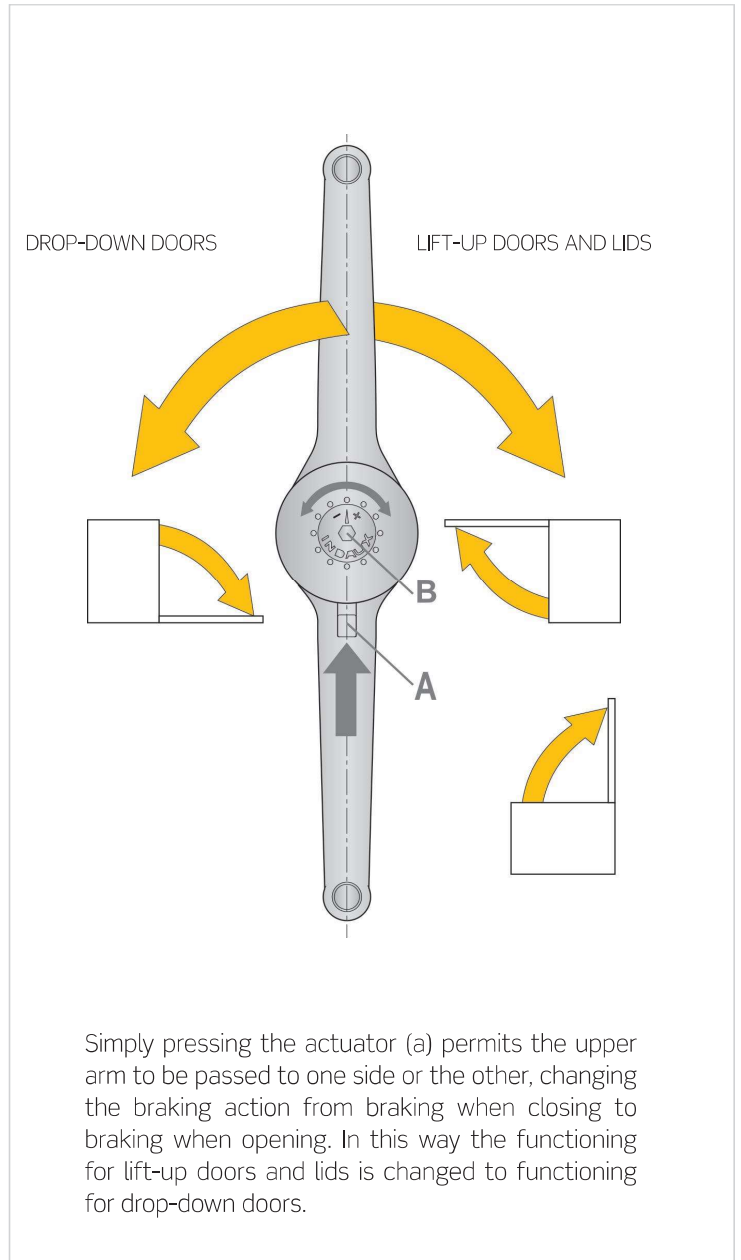

■ Assembly

The fitting is very easy to assemble. When the brackets have been screwed in place independently, the fitting can be fitted into them manually, and it can therefore be supplied separately.

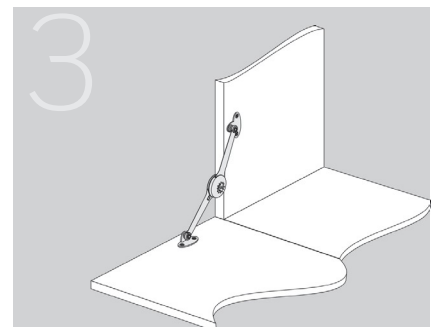
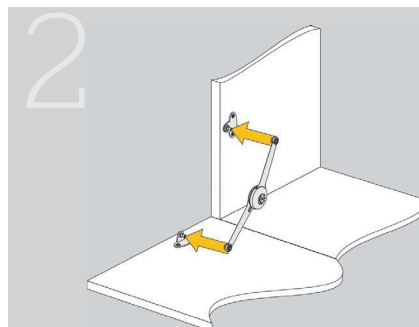
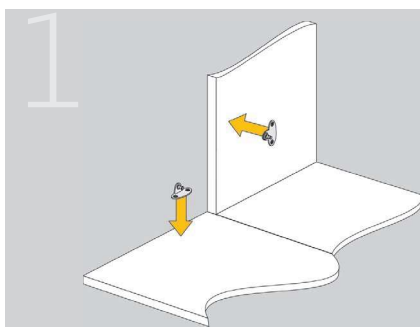

■ Technical data

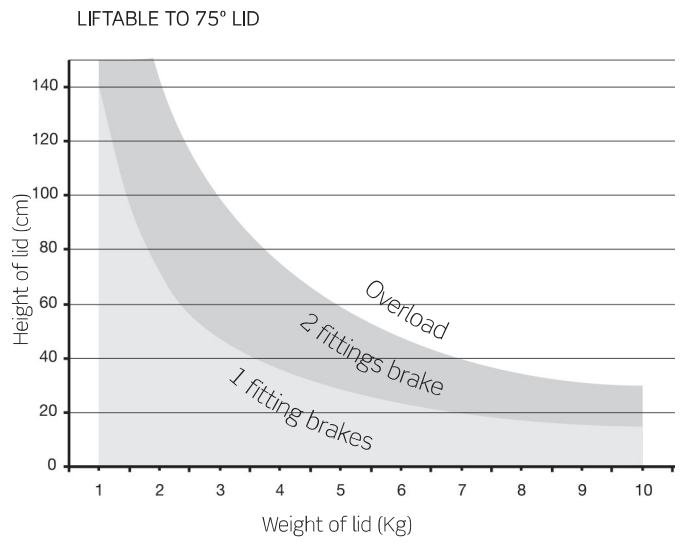
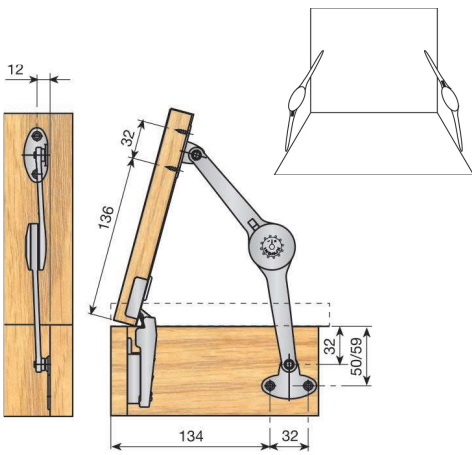
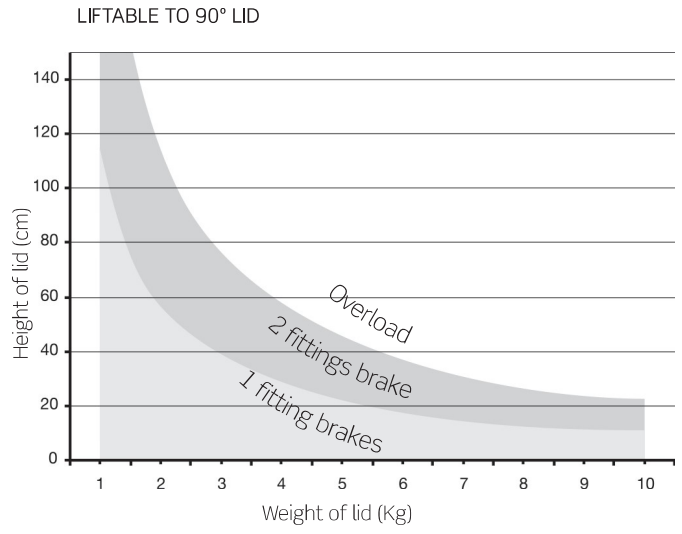
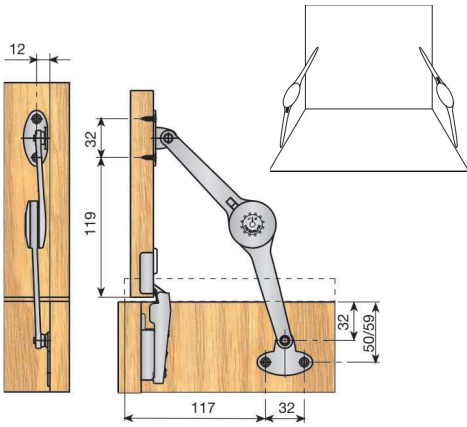

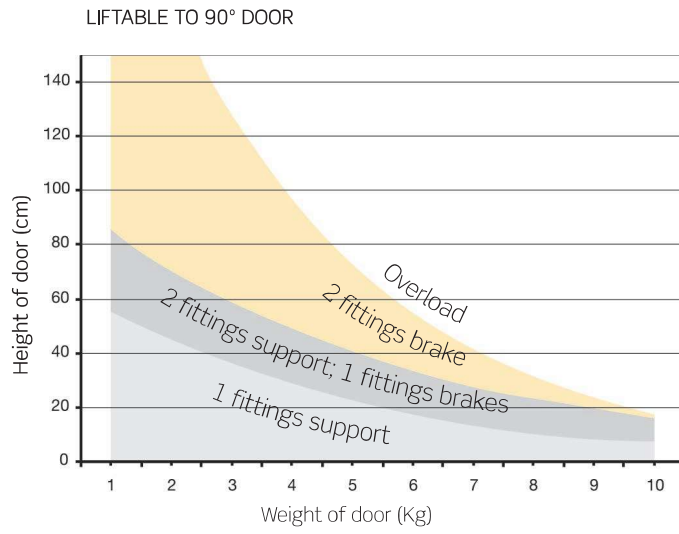
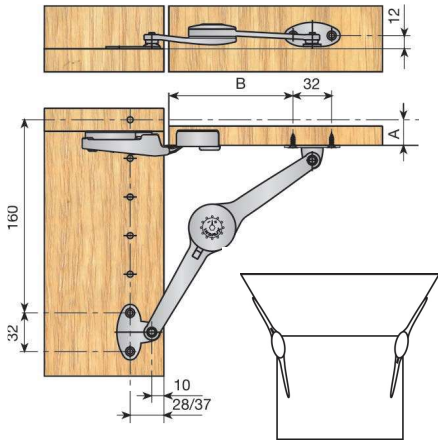

A	B
8	90
9	91
10	92
11	93
12	95
13	96
14	97
15	98
16	99
17	100
18	101
19	102
20	103
21	103
22	104
23	105
24	105
25	106

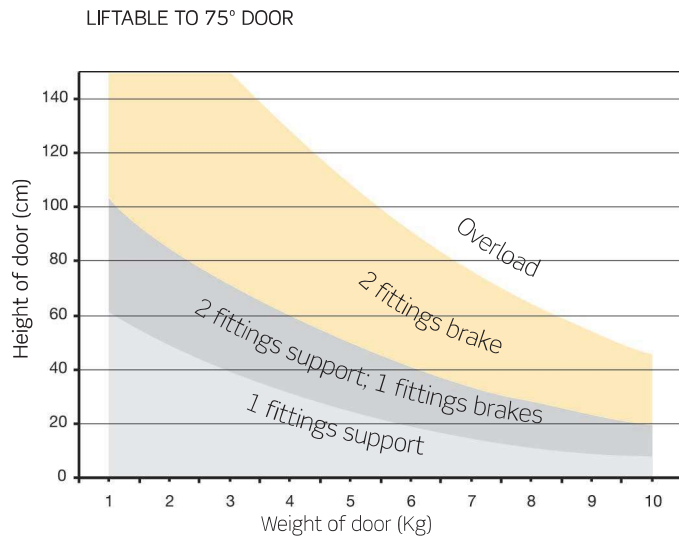
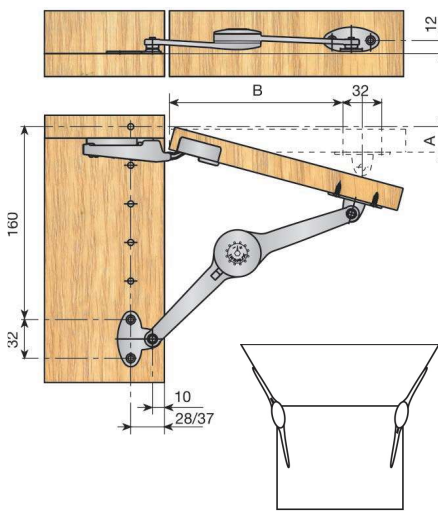

A	B
8	132
9	133
10	134
11	135
12	137
13	138
14	139
15	140
16	141
17	142
18	143
19	143
20	144
21	144
22	145
23	146
24	146
25	147

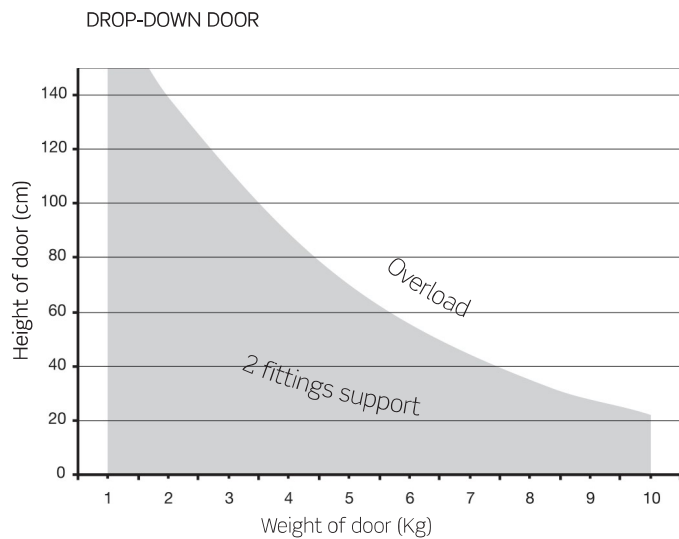
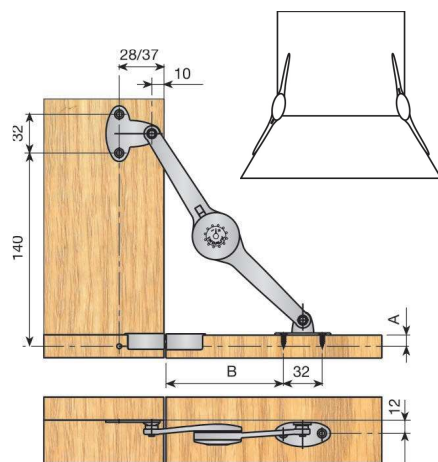

A	B
8	98
9	99
10	100
11	101
12	103
13	104
14	105
15	106
16	107
17	108
18	109
19	110
20	111
21	111
22	112
23	113
24	113
25	114