

7800 SERIES

Partial extension undermount slides for frame and frameless cabinets installation

16mm Drawer installation dimensions(with locking device)

SKW = Internal Drawer Width LW = Internal Cabinet Width

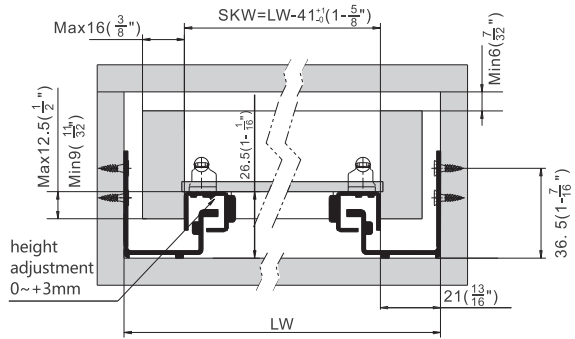

NL(mm)	Runner length (mm)	LT(mm)		AV(mm)
		Max	Min	
229(9")	272	299	284	53
305(12")	329	375	341	72
381(15")	405	451	417	92
457(18")	482	527	494	91
533(21")	558	604	570	91

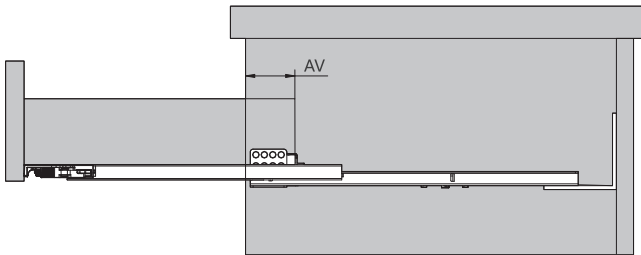

Standard drawer installation dimensions

NL = Nominal Slide Length LT = Internal cabinet Depth

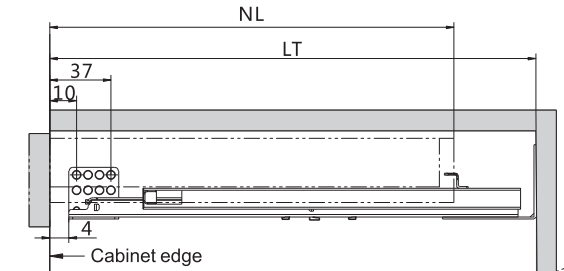

Locking device installation

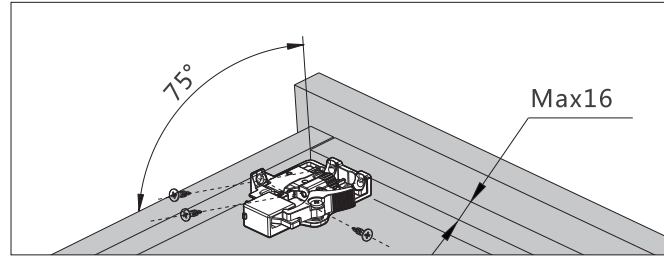

Drawer back preparation

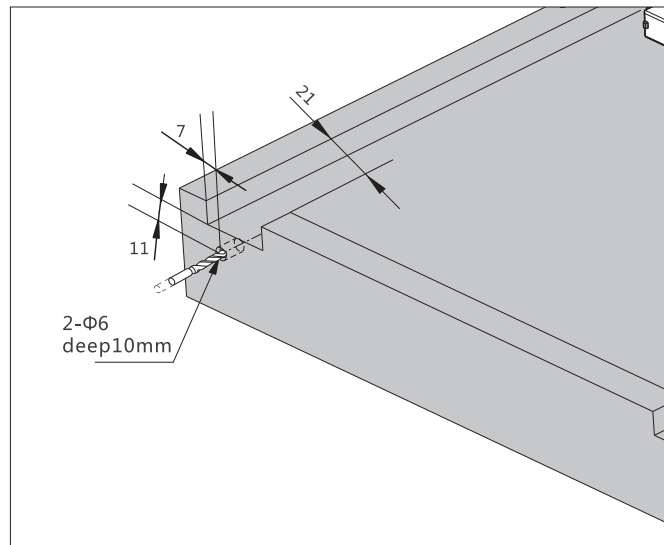

Rear mounting bracket preparation(mm)

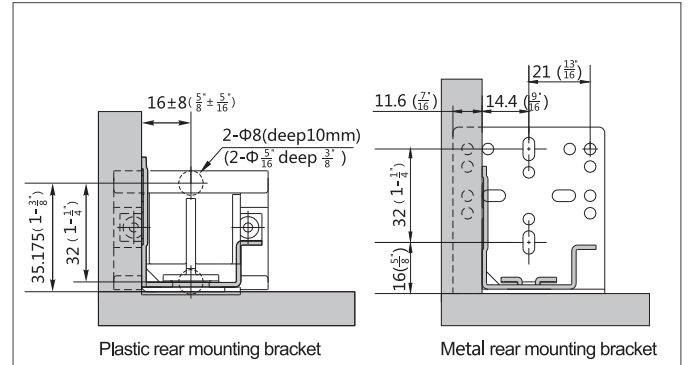

Screw positions of the slides

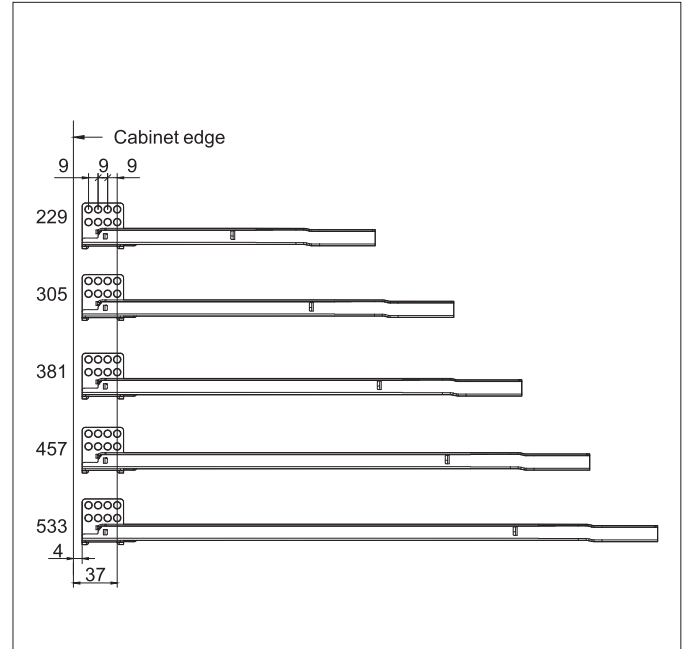

Drawer assembly

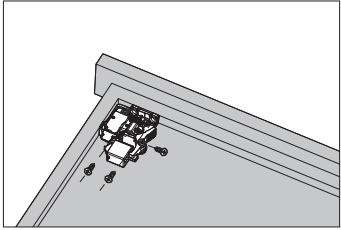

Fix the locking device onto the drawer bottom and fix the rear bracket onto the cabinet back.

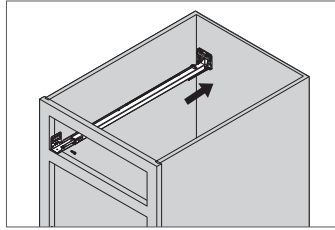
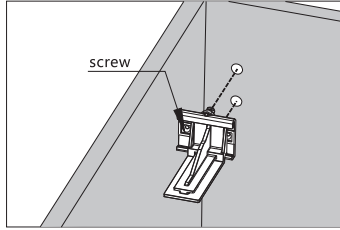

Inset slide end into rear bracket and fix the slide onto the cabinet

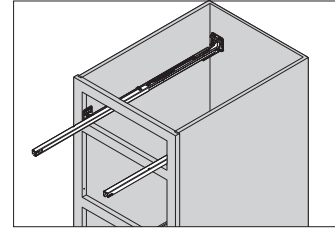

Pull out the slide, lay the drawer bottom onto the slide then push the drawer into the cabinet.

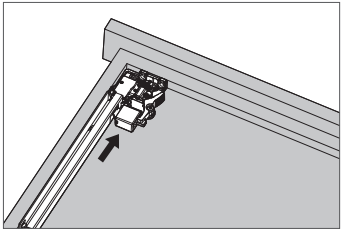
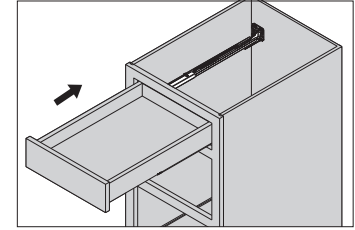

Adjustment

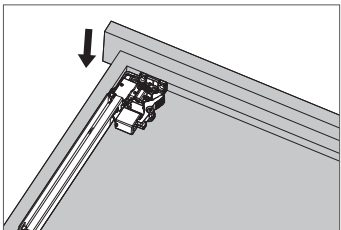

Height adjustment 0~+3mm

Removal

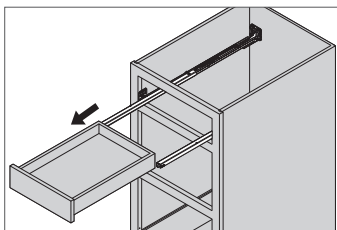
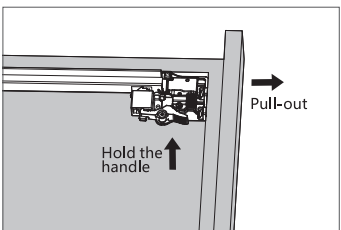

For removal, hold the handle and pull out the drawer.