

RHVBF300SS Ventilator

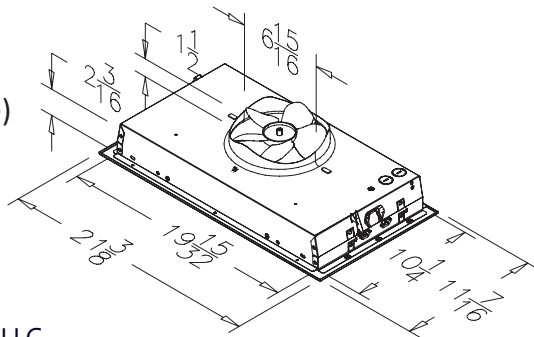

- Bright LED Lights (2):
Wattage: 2.8 W
CCT (color temp.): 3,000K
Lumens: > 250
Rated Life: > 25,000 hrs.

- Stainless Steel finish
- 2-speed rocker switch
- Max CFM: 300
(pre-installation)
- HVI certified CFM: 260 on High (with 7" duct)
- HVI certified CFM: 140 on Low (with 7" duct)
- Sones on High: 7
- Sones on Low: 3
- Quick-release aluminum mesh filter (dishwasher safe)
- Power requirements:
120 VAC, 60 Hz – 2.3 AMPS
- Ducting: Vertical 7" round



Offered by Omega National Products, LLC
(800) 533-8809
www.omeganationalproducts.com