



# 8407

## Specifications

- 1/2" minimum side clearance per side required.
- Triple precision steel ball bearing movement.
- Metal ball bearing retainer for durability and quiet operation.
- Lever disconnect for easy drawer removal and insertion.
- Electro-plated bright zinc chromate with clear lacquered topcoat for better corrosion resistance and appearance. Black zinc chromate finish available.
- Full 32mm pattern with direct access openings for quicker mounting without extending the slide.

*KV8407 Major dimensions and mounting hole locations.*

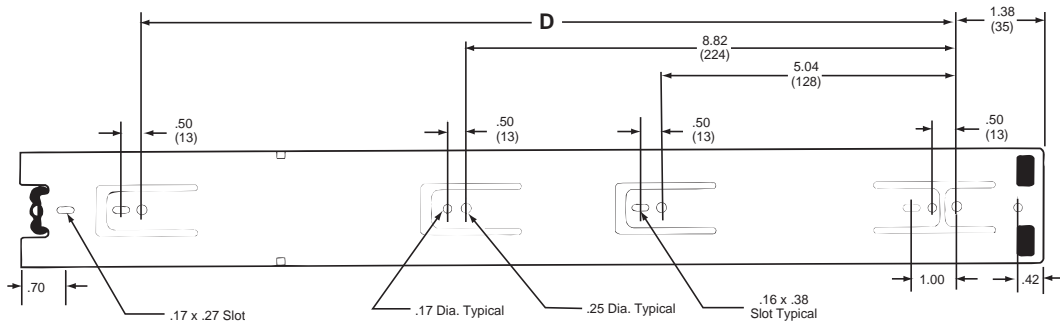
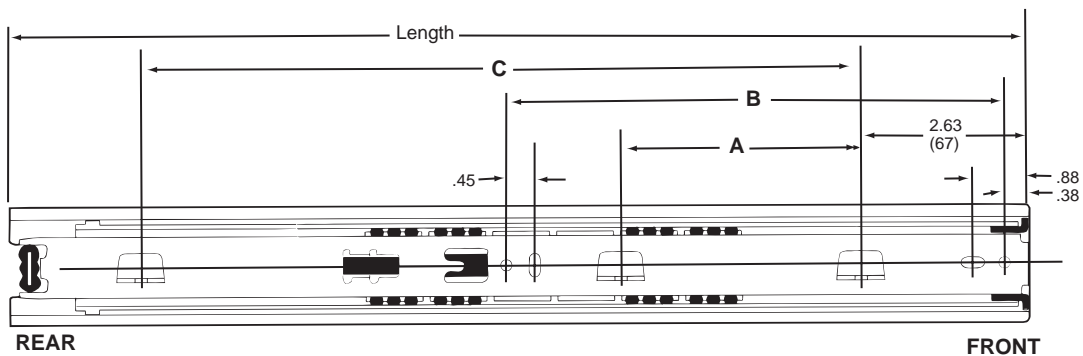

*Dimensions in ( ) are in millimeters.*

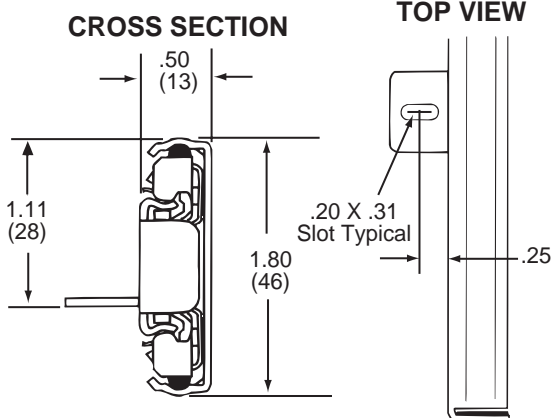

Size	Length	Travel	A	B	C	D
16"	16.00	16.00	3.78 (96)	7.82	11.34 (288)	12.60 (320)
18"	18.00	18.00	3.78 (96)	8.82	11.34 (288)	13.86 (352)
20"	20.00	20.00	6.30 (160)	9.82	15.12 (384)	16.38 (480)
22"	22.00	22.00	7.56 (192)	10.82	15.12 (384)	18.90 (480)
24"	24.00	24.00	7.56 (192)	11.82	15.12 (384)	18.90 (480)

## Installation Instructions for: KV8407 Full Extension, Roll-Out Drawer Slides

For best results, read instructions first.

These instructions show how to install the KV8407 drawer slides. Please note that improper installation may void the Knap & Vogt Limited Lifetime Warranty. To install the slides correctly, follow these instructions, use only KV hardware, and make no modifications.

### Application

- Recommended for use in roll-out trays or similar applications. Not recommended for drawers more than 24" wide.
- Load rating: 100 pound class.
- Requires minimum 1/2" side clearance per side. Drawer width must be 1" to 11/16" less than the drawer opening width.
- Use #7 or #8 pan head screws, such as KV part number 200143-4.
- A pattern of holes is provided for 32mm system mounting with Euro-screws, such as KV part number 200257-2.
- Roll out trays sits on shelf tabs and is secured by screws.
- For use in frame and frameless applications.
- Consult factory for advice on unusual applications. Please note that installation may vary dependent upon the particular application.
- For applications where your products may be used in BIFMA, KCMA, or other applications that are subject to industry standards, the drawer slide you select for usage should be tested within the application and in accordance with the appropriate industry standard. If you have questions or need additional information, please contact Knap & Vogt at the address indicated.

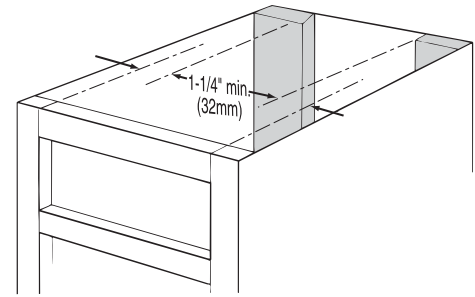

Figure A

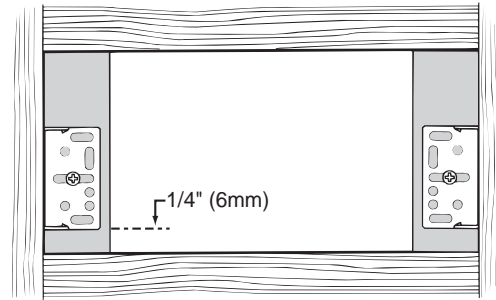

Figure B

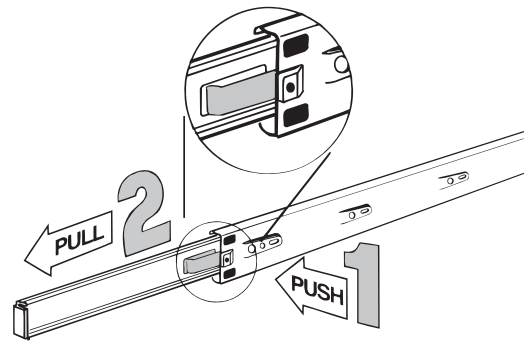

Figure C

### Frame Application

#### **Step 1. Cabinet Preparation**

Fasten two stock 1" by 2" (minimum 3/4" thick by 1 5/8" wide) wood mounting strips to the rear inside wall. Align the strip relative to the face frame, as shown in figure A.

#### **Step 2. Install Rear Bracket**

Locate and mount the KV8402 rear brackets to each mounting strip, as shown in figure B. Install two screws into round holes of each bracket after adjustment.

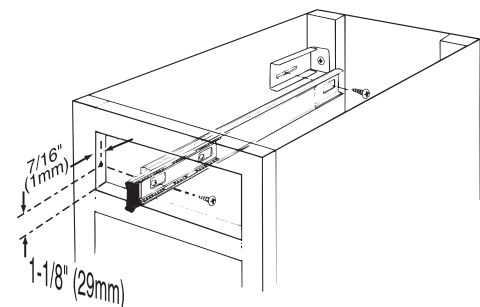

Figure D

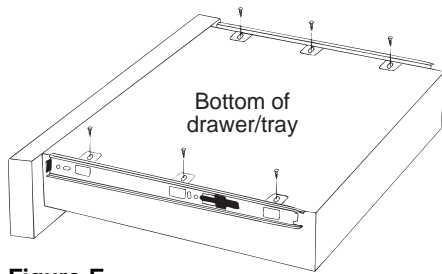

Figure E

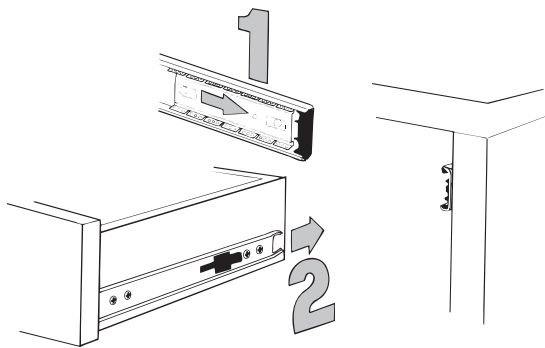

Figure F

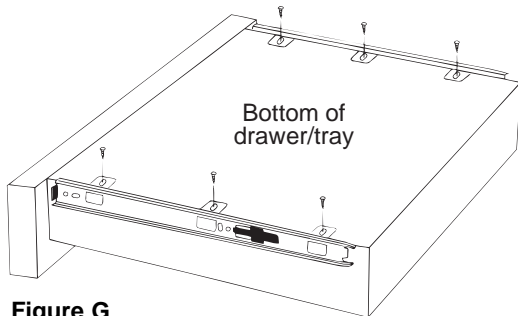

Figure G

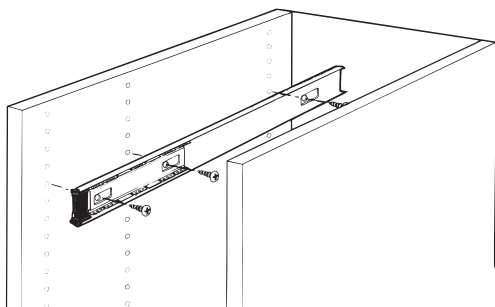

Figure H

### Step 3. Part Preparation and identification

Separate the slide members by depressing the disconnect lever. See figure C. The drawer members are stamped “DR” (drawer right) and “DL” (drawer left) for easier identification. The cabinet members are non-handed.

### Step 4. Install Cabinet Members

Install cabinet members as shown in figure D. Check the location of cabinet members on both sides and adjust as needed. Cabinet member should be flush with front of face frame. Secure slide to rear socket with a screw.

### Step 5. Install Drawer Member

Install the drawer member as shown in figure G. Fasten from bottom through holes in the shelf tabs.

### Step 6. Insert Drawer

Check that ball retainer is latched in the forward position. Insert drawer members and close completely, as shown in figure F.

### Step 7. Adjust and Secure

Open and close drawer while checking for proper fit. Adjust as needed. Secure the drawer member with two screws in the round holes.

### Frameless Application

#### Step 1. Part Preparation and Identification.

Separate the slide members by depressing the disconnect lever, as shown in figure C.

#### Step 2. Install Drawer Members

Install the drawer Member as shown in figure G. Fasten from bottom through holes in the shelf tabs.

#### Step 3. Install Cabinet Members

Install cabinet member as shown in figure H. Check the location of cabinet members on both sides. Adjustment should not be needed when mounted using the 32mm system hole pattern.

#### Step 4. Insert Drawer

Check that ball retainer is latched in the forward position. Insert drawer members and close completely as shown in figure F.

#### Step 5. Adjust and Secure

Open and close drawer while checking for proper fit. Adjust as needed. Secure the drawer member with two screws in the round holes.

### KV8402 Rear Bracket Dimensions

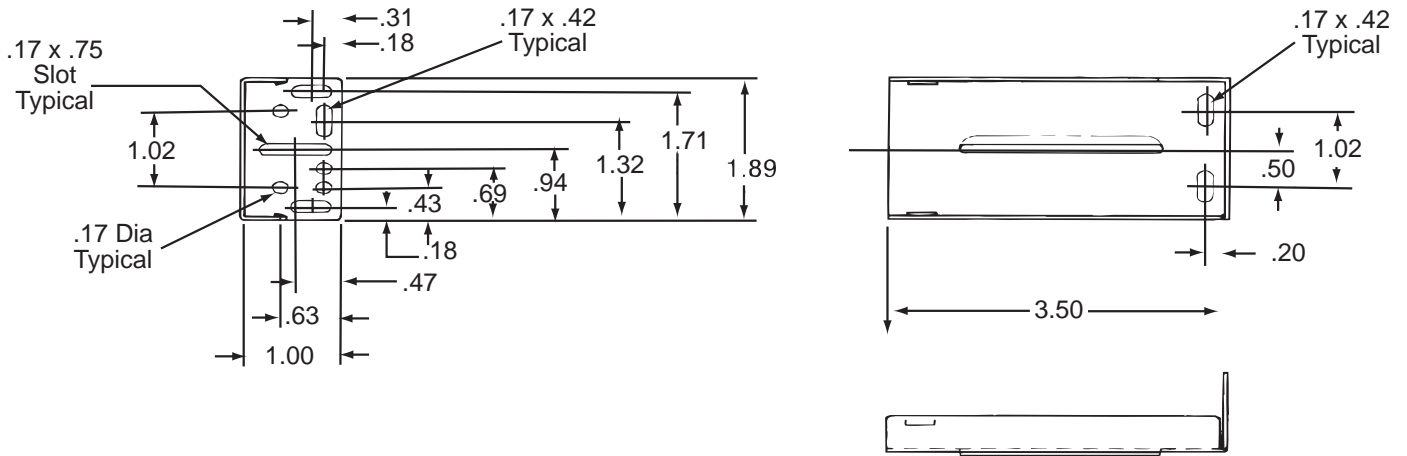

### Limited Lifetime Warranty

Knappe & Vogt Manufacturing Company guarantees its drawer slides and builder's hardware products against failure or defects for so long as the purchaser or end user own them. This warranty is void if any damage to the product is due to misuse, abuse, neglect, accident, improper installation or any used contrary to the instructions accompanying the product. This warranty covers the cost of the defective part and not the cost of removal, installation or other incidental charges. The foregoing are the purchasers exclusive remedies. Knappe & Vogt Manufacturing Company assumes no liability for special or consequential damages.

Replacement product may be obtained by returning the product, transportation charges prepaid, together with a receipt of purchase or other documents acknowledging the sale of the product, addressed to the Knappe & Vogt Manufacturing Company, Attention: Customer Service Department.

The warranty set forth above is in lieu of any other warranties, express or implied, including warranties of merchantability and fitness for use.

