

Hinges



CLIP top 95° Glass Door



Features

- For glass thickness of 4.5 mm to 7 mm
- Side adjustment of +0.5 mm to -3.5 mm
- Three-dimensional adjustment
- Fixing screws included (605.1100)
- 26 mm drill bit required (1" cannot be used)



Minimum reveal table				
5.5	0	0	0	0
6	0	0	0	0
6.5	0	0	0	0
7	0	0	0	0
B = boring distance	4.5	5	6	7
	T = door thickness			

Thickness greater than 7 trial recommended

Overlay

Frameless

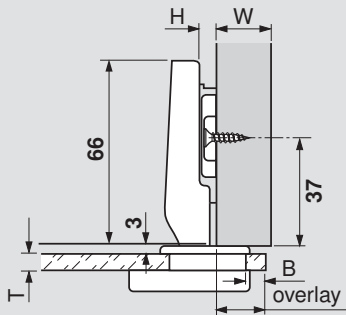

Partial/twin overlay

Frameless

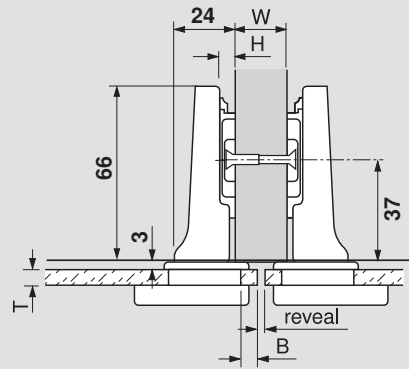

Inset

Frameless

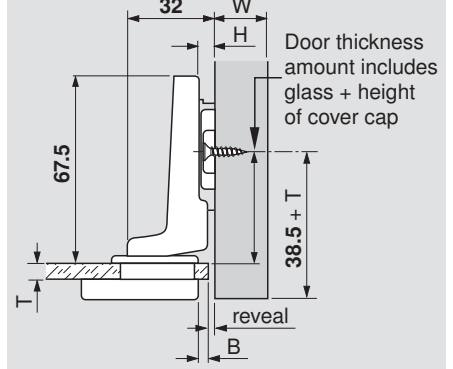

Cover caps for door front

D-shape cap



Round cap

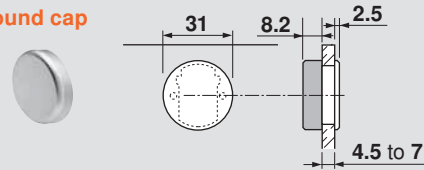

- Required on door front
- D-shape available in polished chrome
- Round available in black and polished chrome

	Part no.
D-shape cover cap	84.4120
Round cover cap	84.4140

Boring pattern

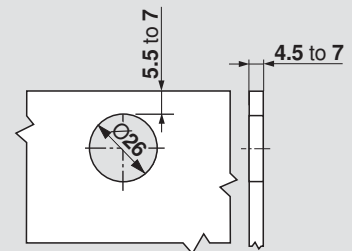

H	Overlay				P	S
0	15.5	16	16.5	17	6	19
3	12.5	13	13.5	14	9	22
6	9.5	10	10.5	11	12	25
9	6.5	7	7.5	8	15	28
	5.5	6	6.5	7	Fixed distance = 10	
	B = boring distance					

H	Reveal				W	P	S
0	4	3	1	0.5	16	15	24
	7	6	5	4	19		
	10	9	8	7	22		
	5.5	6	6.5	7	Fixed distance = .5		
	B = boring distance						

H	Reveal				P	S
0	2.5	2	1.5	1	23.5	32
	5.5	6	6.5	7	Fixed distance = -8	
	B = boring distance					

Abbreviations

H	= Plate height
P	= Door protrusion
S	= Side arm protrusion
T	= Door thickness
W	= Side panel width

Straight-arm	Self close
Screw-on	75T4100

Half-cranked	Self close
Screw-on	75T4200

Full-cranked	Self close
Screw-on	75T4300